



Fig.1 View of MUR26.

DESCRIPTION

The MUR26 is six relay module which converts two analog input signals 0 - 10V to any digital combination of outputs. Relays have SPST-NO contacts. Input signals, processed by 10-bit analog to digital converters with 10mV sensitivity, generate implemented arithmetic, logical and time functions. Signals can be treated as two independent channels. The module is individually programmed on request of the customer considering input voltages, time dependencies, hysteresis, switching thresholds and output logical states. LED diodes indicate output states.

TECHNICAL DATA

Power supply	24 V AC/DC \pm 10%
Max. current consumption	130mA for 24V AC, 60mA for 24V DC
Input resistance	100k Ω
Operating input voltage	0 – 10V
Sensitivity	10mV
Resolution	individually established
Input signal settling time	individually established
Hysteresis width	individually established
Contacts switching capacity	
alternating current $\cos\phi=1$	380V, 8A [2000VA]
direct current	32V, 8A
Mechanical endurance of contacts	2×10^7 operations
Protection class of the case / terminals	IP-40 / IP-20
Ambient temperature range	-10...+55° C
Diameter of terminals	2,5 mm ²
Protections	against reverse polarization
Mounting	DIN-35 or DIN-32 rail
Dimensions (L x W x H)	96mm x 70,5mm x 42mm
Weight	190 g

MUR26

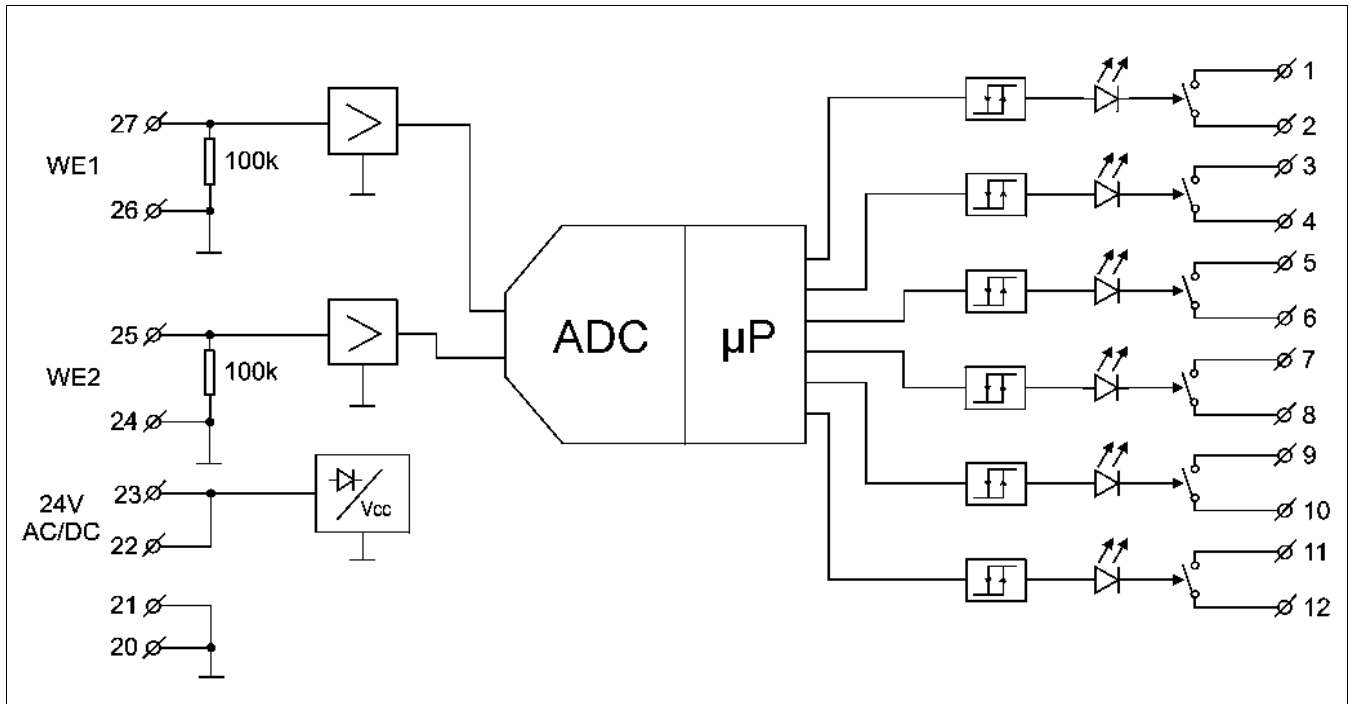

Fig. 2 Connections of MUR26.

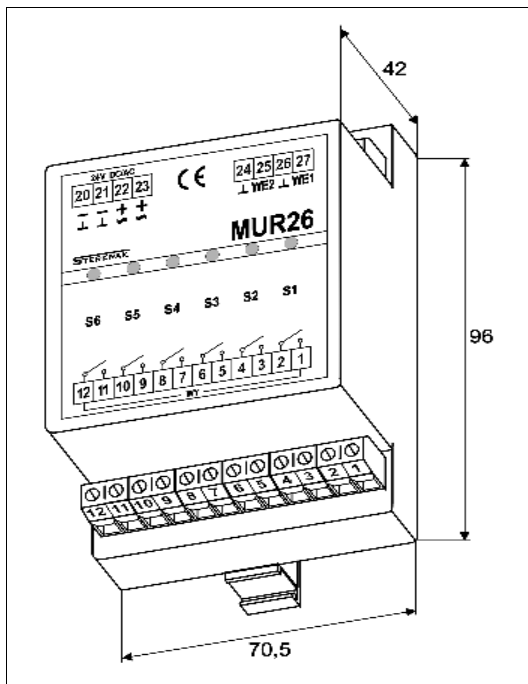

Fig. 3 Dimensions of MUR26.

$f(U_{WE1}, U_{WE2})[V]$ rising	$f(U_{WE1}, U_{WE2})[V]$ falling	S_6	S_5	S_4	S_3	S_2	S_1
Transfer function, individually established							

adjust accuracy $\pm 0,5\%$

July 2004