

Fig.1 View of USS136.

DESCRIPTION

The USS136 is functional equivalent of the MCAS6-6 module, which converts analog input signal 0 - 10V to seven discrete output states. Relays have SPST-NO contacts. Built-in signal level detection circuit for input voltage allows force logic states omitting transient states. **Input signal settling time** is an important parameter. It is set typically to 20ms and can be modified on request of the customer. This time should be equal or greater than output signal settling time of the controller. The hysteresis circuit prevents contacts from "flickering" in switching points. LED diodes indicate output states.

TECHNICAL DATA

Power supply	24 V AC/DC \pm 10%
Max. current consumption	130 mA for 24 V AC, 60 mA for 24 V DC
Input resistance	100k Ω
Operating input voltage	0 – 10V
Input signal settling time	20 ms
Hysteresis width	0,4V
Contacts switching capacity alternating current $\cos\phi=1$ direct current	380V, 8A [2000VA] 32V, 8A
Mechanical endurance of contacts	2×10^7 operations
Protection class of the case / terminals	IP-40 / IP-20
Ambient temperature range	-10...+55° C
Diameter of terminals	2,5 mm ²
Protections	against reverse polarization
Mounting	DIN-35 or DIN-32 rail
Dimensions (L x W x H)	96mm x 70,5mm x 42mm
Weight	190 g

USS136

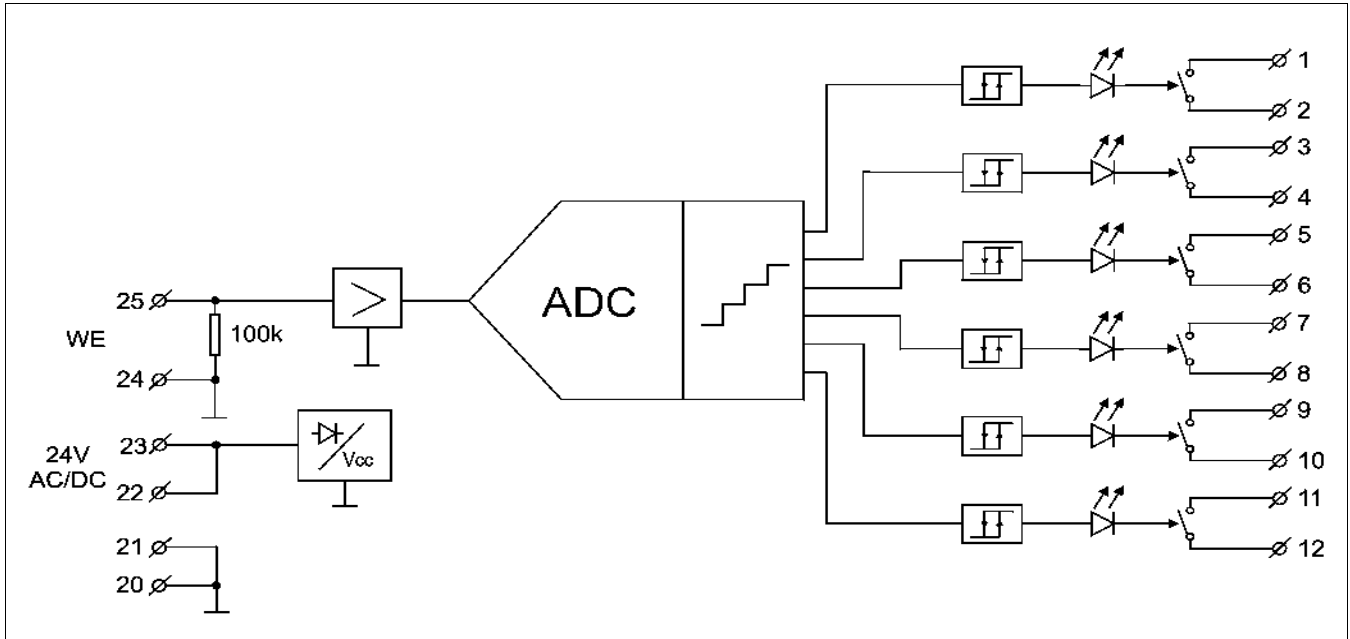

Fig.2 Connections of USS136.

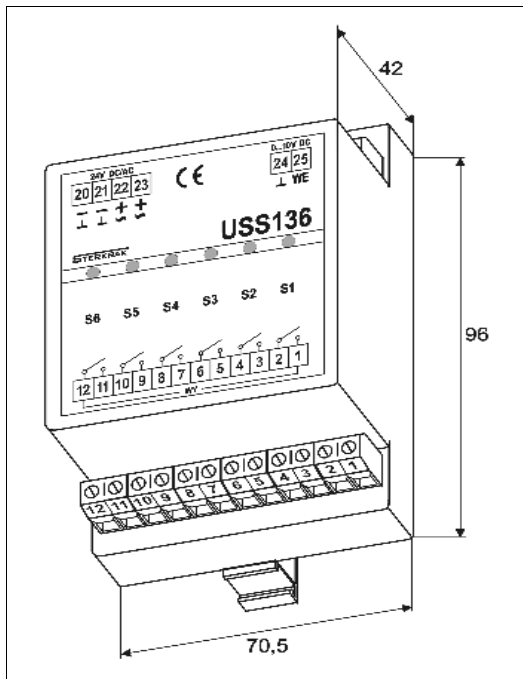

Fig.3 Dimensions of USS136.

U_{WE} [V] rising	U_{WE} [V] falling	S ₆	S ₅	S ₄	S ₃	S ₂	S ₁
0	0	○	○	○	○	○	○
1,7	1,3	○	○	○	○	○	●
3,2	2,8	○	○	○	○	●	●
4,7	4,3	○	○	○	●	●	●
6,2	5,8	○	○	●	●	●	●
7,7	7,3	○	●	●	●	●	●
9,2	8,8	●	●	●	●	●	●

adjust accuracy $\pm 0,5\%$

● - closed contacts, LEDs switched-on

○ - opened contacts, LEDs switched-off

ATTENTION:

Hysteresis width, thresholds and input signal settling time can be individually established according to the specification.

June 2004