

Fig.1 View of USS136OC.

## DESCRIPTION

The USS136OC has six galvanic separated, OC type discrete outputs. The module converts analog input signal 0 – 10 V to seven discrete output states. Built-in signal level detection circuit for input voltage allows force logic states, omitting transient states. **Input signal settling time** is an important parameter. It is set typically to 20ms and can be modified on request of the customer. This time should be equal or greater than output signal settling time of the controller. The hysteresis circuit prevents contacts from "flickering" in switching points. LED diodes indicate output states.

## TECHNICAL DATA

Power supply	24 V AC/DC $\pm$ 10%
Max. current consumption	76mA for 24V AC, 35mA for 24V DC
Input resistance	100k $\Omega$
Operating input voltage	0 – 10V
Input signal settling time	20ms
Hysteresis width	0,4V
Output signal	unpotential contact - OC type
Max. output current	50mA
Max. Collector-Emitter voltage	30V
Max. output power dissipation	150mW
Protection class of the case / terminals	IP-40 / IP-20
Ambient temperature range	-10...+55° C
Diameter of terminals	2,5 mm <sup>2</sup>
Protections	against reverse polarization
Mounting	DIN-35 or DIN-32 rail
Dimensions (L x W x H)	96mm x 70,5mm x 42mm
Weight	135 g

# USS1360C

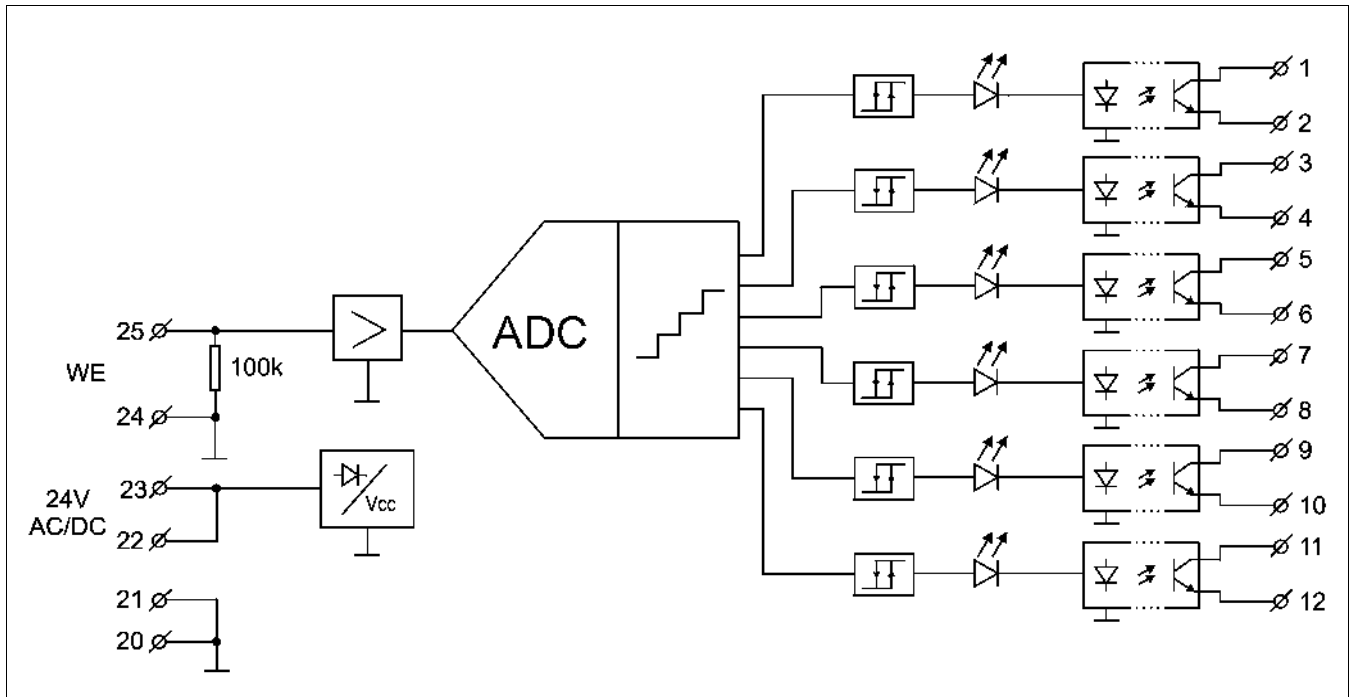

Fig.2 Connections of USS1360C.

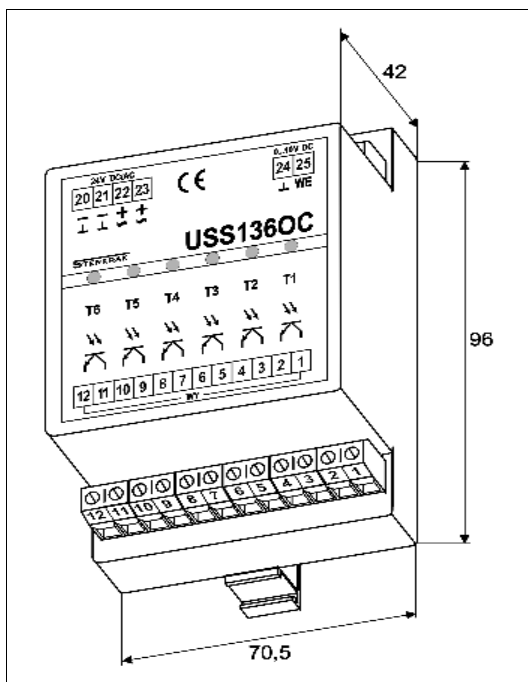

Fig.3 Dimensions of USS1360C.

$U_{WE}$ [V] rising	$U_{WE}$ [V] falling	T <sub>6</sub>	T <sub>5</sub>	T <sub>4</sub>	T <sub>3</sub>	T <sub>2</sub>	T <sub>1</sub>
0	0	○	○	○	○	○	○
1,7	1,3	○	○	○	○	○	●
3,2	2,8	○	○	○	○	●	●
4,7	4,3	○	○	○	●	●	●
6,2	5,8	○	○	●	●	●	●
7,7	7,3	○	●	●	●	●	●
9,2	8,8	●	●	●	●	●	●

adjust accuracy  $\pm 0,5\%$

● - transistors conduct, LEDs switched-on

○ - transistors not conduct, LEDs switched-off

### ATTENTION:

Hysteresis width, thresholds and input signal settling time can be individually established according to the specification.

September 2004