



Fig.1 View of USW22.

## DESCRIPTION

The USW22 is module which controls operation of the fan. It is powered from 230V AC lines and serves for periodical ventilation of rooms, as well as for short ventilation, for example after turning on the lighting. The triac with zero voltage crossing is main working element. Built-in SW1 and SW2 switches allow change break duration of the fan and delay work time after turning off the lighting. The LED diode indicates an output state.

## PRINCIPLE OF OPERATION

USW22 module can work in two modes:

**Work mode** – periodically actuating the fan for 30 minutes every 4, 8, or 12 hours. Break time of the fan is set by SW2 switch, according to Table 2. After turning on the lighting, the module waits 1 minute, and then actuate the fan. After 3, 6, 9 or 12 minutes from turning off the lighting – fan is stopped. This delay is set by SW1 switch, according to Table 1.

**Test mode** – set by SW2 switch (Table 2). This mode serves for correctness check of the whole system. The fan is periodically actuated every 45 s for 15s. After turning on the lighting, the module waits 3 s, and then actuate the fan. After turning off the lighting the module counts 3, 6, 9 or 12 s, and then stops the fun. This delay is set by SW1 switch according to Table1.

**ATTENTION:** New settings of switches are valid in the next working cycle, or after momentary turning off the power.

## TECHNICAL DATA

Power supply	230 V AC $\pm$ 10%
Max. current consumption for $R_L = \infty$	20 mA AC
Output circuit	triac with zero voltage crossing
RMS on-state current	3A AC
Max. peak on-state current, $t=20ms$	100A AC
Protection class of the case / terminals	IP-40 / IP-20
Ambient temperature range	-10...+55° C
Diameter of terminals	2,5 mm <sup>2</sup>
Mounting	DIN-35 or DIN-32 rail
Dimensions (L x W x H)	96mm x 48mm x 42mm
Weight	80 g

# USW22

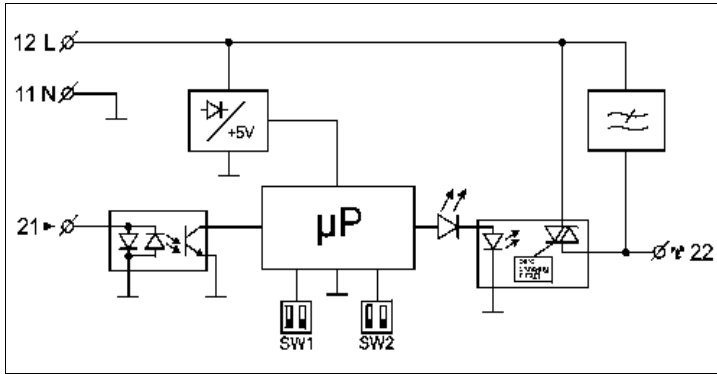

Fig. 2 Block diagram of USW22.

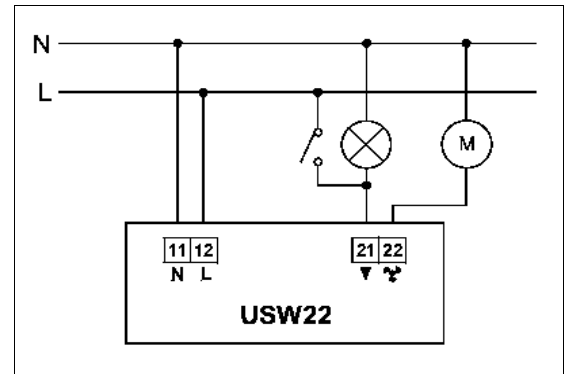

Fig. 3 Connections of USW22.

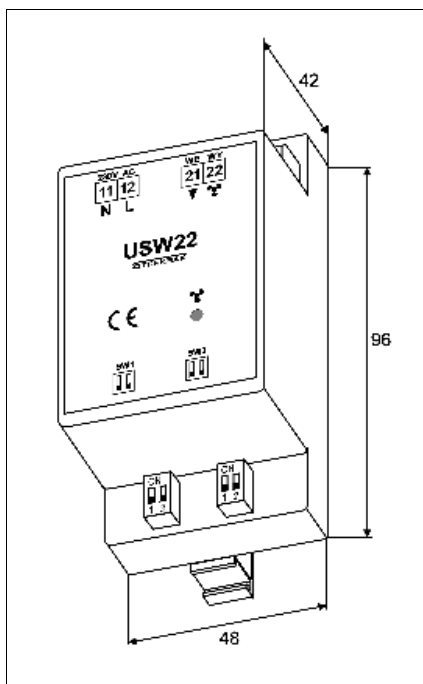

Fig. 3 Dimensions of USW22.

SW1	Delay times	
	Work mode	Test mode
	3 min.	3 s
	6 min.	6 s
	9 min.	9 s
	12 min.	12 s

Table 1

SW2	Break time
	4 h
	8 h
	12 h
	Test mode

Table 2

### ATTENTION:

Working and breaking times of the fun, as well as reaction way on the lighting, can be individually established.



**Before any connecting operations it is necessary to disconnect 230V AC power line. Touching terminals 11, 12 and 21, 22 during work of the module is threatened with electric shock.**



July 2004