



Fig.1 View of UWI.

## DESCRIPTION

The UWI is applied in measurement systems to delay impulses. It can be connected to transistor transmitter (OC type) as well as to reed relay (relay). Length of output impulse is regulated from 1,5 to 3,6 s. The LED diode indicates an output state. The module contains lowpass filter in order to eliminate possible interferences. Minimum duration of input signal is 1,6 ms (max. 310Hz for duty cycle 50%).

## TECHNICAL DATA

Power supply	24 V AC/DC $\pm$ 10%
Current consumption	16 mA for 24 V AC 12 mA for 24 V DC
Minimal duration of input impulse	1,6 ms
Output signal	12V DC, max. 10 mA
Duration of output impulse	1,5 to 3,6 s
Factory set of output impulse duration	2,8 s $\pm$ 1%
Protection class of the case	IP-40
Protection class of terminals	IP-20
Ambient temperature range	-10...+55° C
Diameter of terminals	2,5 mm <sup>2</sup>
Protections	against reverse polarization
Mounting	DIN-35 or DIN-32 rail
Dimensions (L x W x H)	96mm x 27mm x 42mm
Weight	50 g

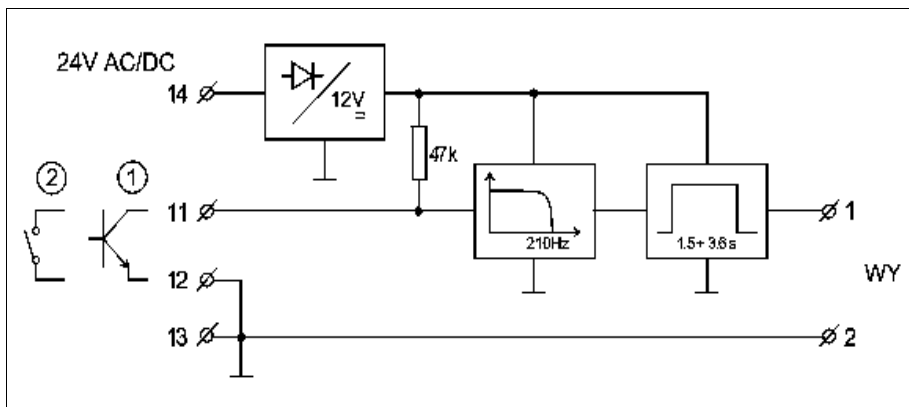

- ① Transistor transmitter
- ② Reed relay transmitter

Fig.2 Connections of UWI.

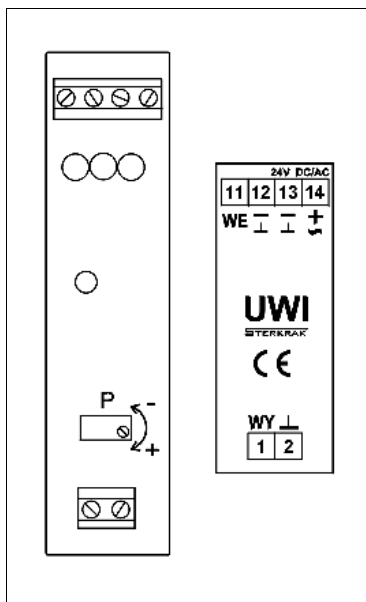

Fig.3 Regulation method.  
P- multiturn potentiometer

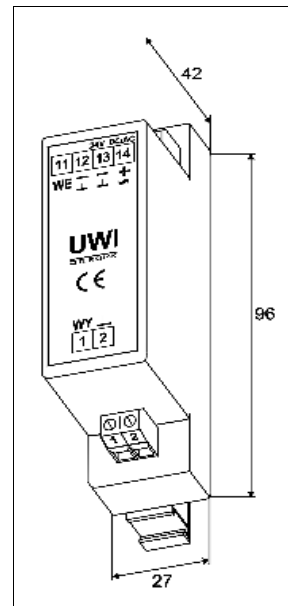

Fig.4 Dimensions of UWI.

One full turn of potentiometer axle:

- to the left ("-") direction) shorten the impulse duration to about 100 ms,
- to the right ("+" direction) lengthen the impulse duration to about.100 ms.