

Fig.1 View of UWIS.

## DESCRIPTION

The UWIS is applied in measurement systems to delay impulses. The module has galvanic separated, OC type discrete output. It can be connected to transistor transmitter (OC type) as well as to reed relay (relay). Length of output impulse is regulated from 1,5 to 3,6 s. The LED diode indicates an output state. The module contains lowpass filter in order to eliminate possible interferences. Minimum duration of input signal is 1,6 ms (max. 310Hz for duty cycle 50%).

## TECHNICAL DATA

Power supply	24 V AC/DC $\pm$ 10%
Current consumption AC / DC	20 mA / 12 mA
Minimal duration of input impulse	1,6 ms
Output signal	unpotential contact - OC type
Duration of output impulse	1,5 to 3,6 s
Factory set of output impulse duration	1,5 s $\pm$ 1%
Max. output current	50 mA
Max. Collector-Emitter voltage	35 V
Max. output power dissipation	150 mW
Protection class of the case / terminals	IP-40 / IP-20
Ambient temperature range	-10...+55° C
Diameter of terminals	2,5 mm <sup>2</sup>
Protections	against reverse polarization
Mounting	DIN-35 or DIN-32 rail
Dimensions (L x W x H)	96mm x 27mm x 42mm
Weight	50 g

# UWIS

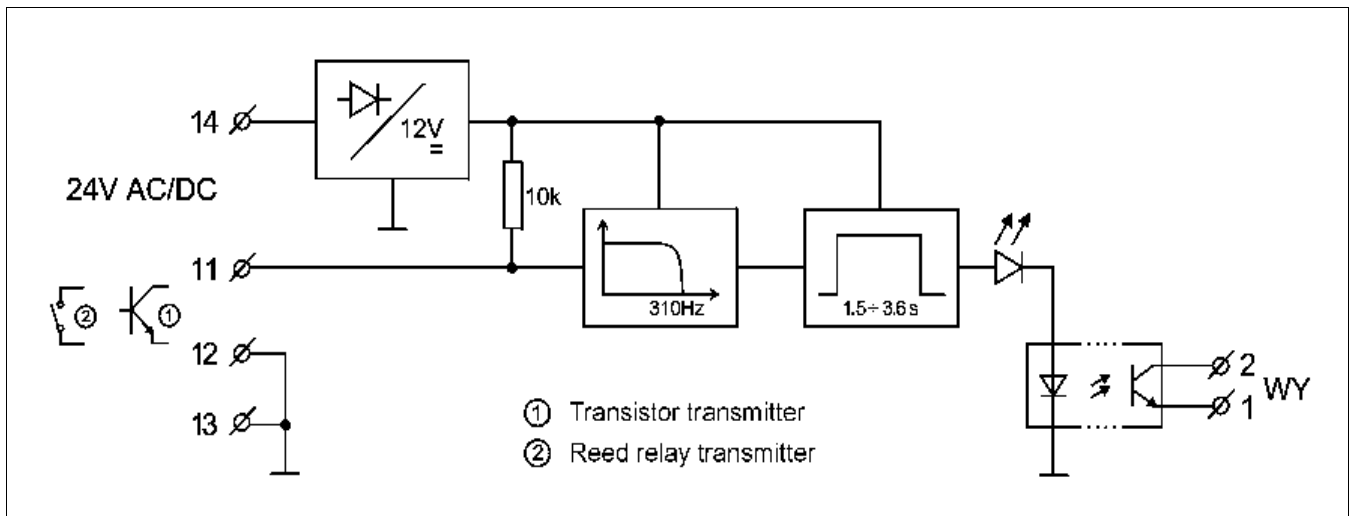

Fig.2 Connections of UWIS.

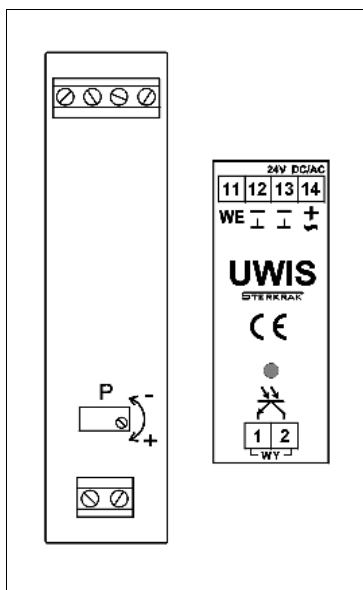

Fig.3 Regulation method.  
P- multiturn potentiometer

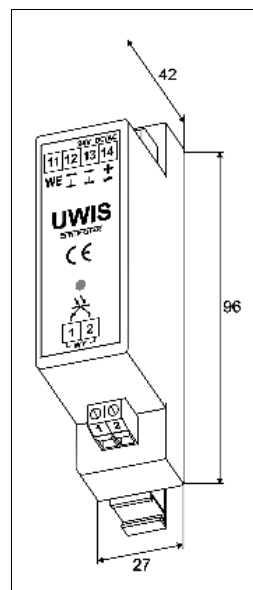

Fig.4 Dimensions of UWIS.

One full turn of potentiometer axle:

- to the left ("- direction) shorten the impulse duration to about 100 ms,
- to the right ("+" direction) lengthen the impulse duration to about.100 ms.

September 2004