

Fig.1 The PAC16 module.

APPLICATION

The relay module used to work as an executive element with an analog output of the controller to activate peripheral equipment requiring greater power.

DESCRIPTION

The PAC16 is six relay module that converts the analog input signal (0 - 10V) from the controller to 64 discrete, voltageless output states. Relays have SPST-NO contacts. Built-in input voltage level detection circuit allows enforce logical signals without transition states (no short switching of contacts). An important parameter is **the input signal settling time**. Typically it is 400ms and can be adapted to the needs of the customer in the range of 20ms up to several minutes. Time should be chosen to be equal to or greater than the output signal settling time of the controller, which proofing the module for short-term interference. The hysteresis circuit prevents contacts from "flickering" in switching points. LED diodes indicate output states according to enclosed diagram.

TABLE OF STATES

State	OPP [V]	S1	S2	S3	S4	S5	S6	State	OPP [V]	S1	S2	S3	S4	S5	S6
0	0,00	○	○	○	○	○	○	32	4,80	○	○	○	○	○	●
1	0,15	●	○	○	○	○	○	33	4,95	●	○	○	○	○	●
2	0,30	○	●	○	○	○	○	34	5,10	○	●	○	○	○	●
3	0,45	●	●	○	○	○	○	35	5,25	●	●	○	○	○	●
4	0,60	○	○	●	○	○	○	36	5,40	○	○	●	○	○	●
5	0,75	●	○	●	○	○	○	37	5,55	●	○	●	○	○	●
6	0,90	○	●	●	○	○	○	38	5,70	○	●	●	○	○	●
7	1,05	●	●	●	○	○	○	39	5,85	●	●	●	○	○	●
8	1,20	○	○	○	●	○	○	40	6,00	○	○	○	●	○	●
9	1,35	●	○	○	●	○	○	41	6,15	●	○	○	●	○	●
10	1,50	○	●	○	●	○	○	42	6,30	○	●	○	●	○	●
11	1,65	●	●	○	●	○	○	43	6,45	●	●	○	●	○	●
12	1,80	○	○	●	●	○	○	44	6,60	○	○	●	●	○	●
13	1,95	●	○	●	●	○	○	45	6,75	●	○	●	●	○	●
14	2,10	○	●	●	●	○	○	46	6,90	○	●	●	●	○	●
15	2,25	●	●	●	●	○	○	47	7,05	●	●	●	●	○	●
16	2,40	○	○	○	○	●	○	48	7,20	○	○	○	○	●	●
17	2,55	●	○	○	○	●	○	49	7,35	●	○	○	○	●	●
18	2,70	○	●	○	○	●	○	50	7,50	○	●	○	○	●	●
19	2,85	●	●	○	○	●	○	51	7,65	●	●	○	○	●	●
20	3,00	○	○	●	○	●	○	52	7,80	○	○	●	○	●	●
21	3,15	●	○	●	○	●	○	53	7,95	●	○	●	○	●	●
22	3,30	○	●	●	○	●	○	54	8,10	○	●	●	○	●	●
23	3,45	●	●	●	○	●	○	55	8,25	●	●	●	○	●	●
24	3,60	○	○	○	●	●	○	56	8,40	○	○	○	●	●	●
25	3,75	●	○	○	●	●	○	57	8,55	○	○	○	●	●	●
26	3,90	○	●	○	●	●	○	58	8,70	○	●	○	●	●	●
27	4,05	●	●	○	●	●	○	59	8,85	●	●	○	●	●	●
28	4,20	○	○	●	●	●	○	60	9,00	○	○	●	●	●	●
29	4,35	●	○	●	●	●	○	61	9,15	●	○	●	●	●	●
30	4,50	○	●	●	●	●	○	62	9,30	○	●	●	●	●	●
31	4,65	●	●	●	●	●	○	63	9,45	●	●	●	●	●	●

OPP - optimal switching point
 ○ - opened contacts
 ● - closed contacts

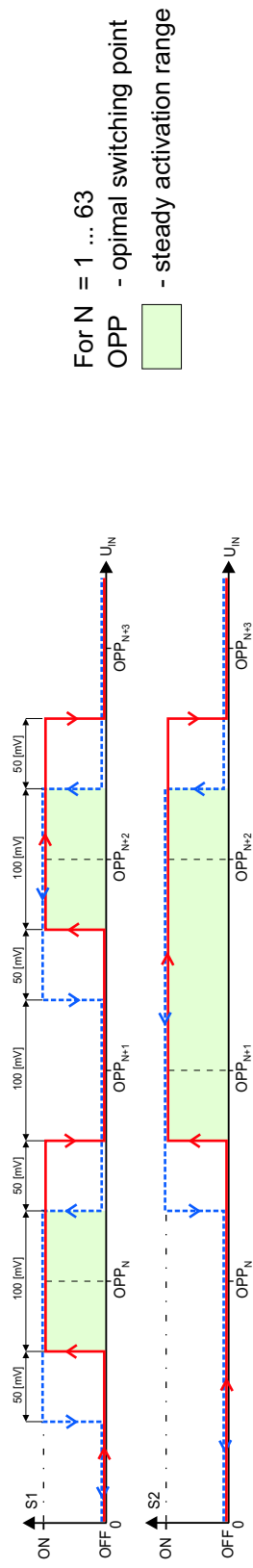

Fig. 2 Principle of switching.

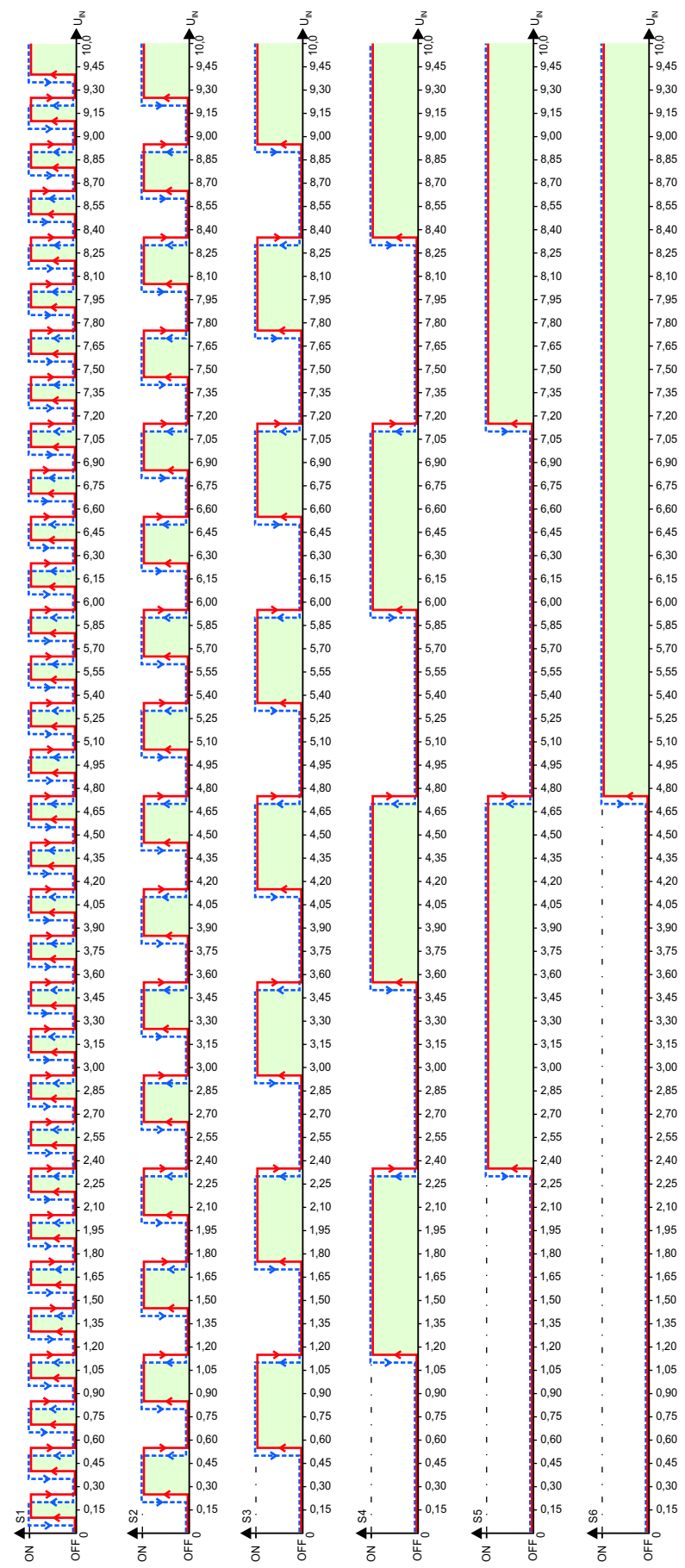

Fig. 3 Switching diagram.

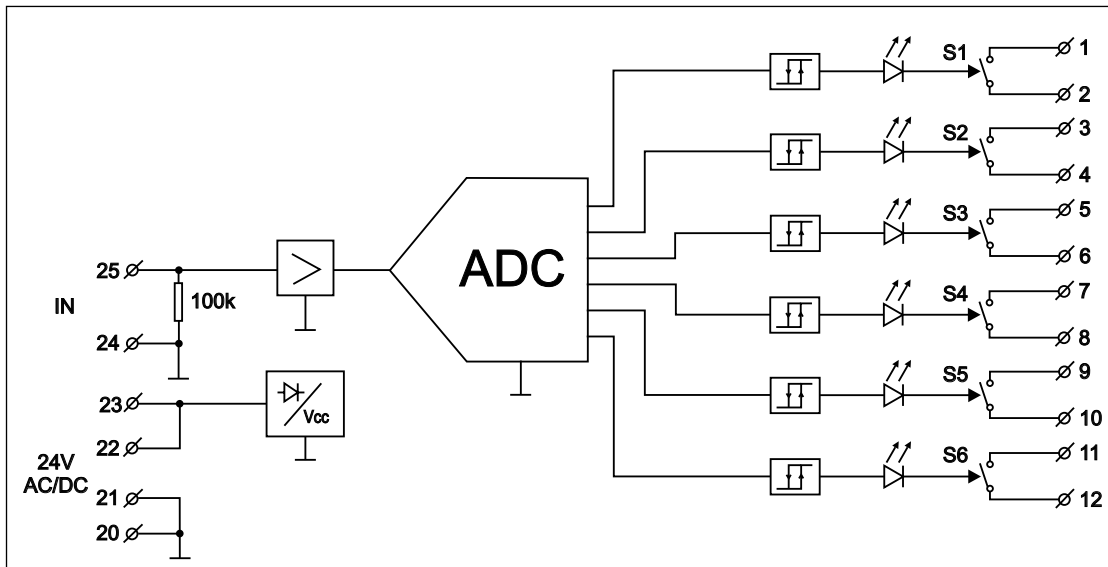

Fig.4 Connections of the PAC16.

TECHNICAL DATA

Power supply	24 V AC/DC \pm 10%
Max. current consumption	130 mA for 24 V AC 60 mA for 24 V DC
Input resistance	100k Ω
Input voltage	0 - 10V
Sensitivity	10mV
Input signal settling time	400ms
Hysteresis width	50mV
Contact switching capacity alternating current $\cos\phi=1$ direct current	380V, 8A [2000VA] 32V, 8A
Mechanical endurance of contacts	2×10^7 operations
Protection class of the case	IP-40
Protection class of terminals	IP-20
Ambient temperature range	-10...+55°C
Diameter of terminals	2,5 mm ²
Protections	against reverse polarisation
Mounting	DIN-35 or DIN-32 rail
Dimensions (L x W x H)	96mm x 70,5mm x 42mm
Weight	190 g

PAC16

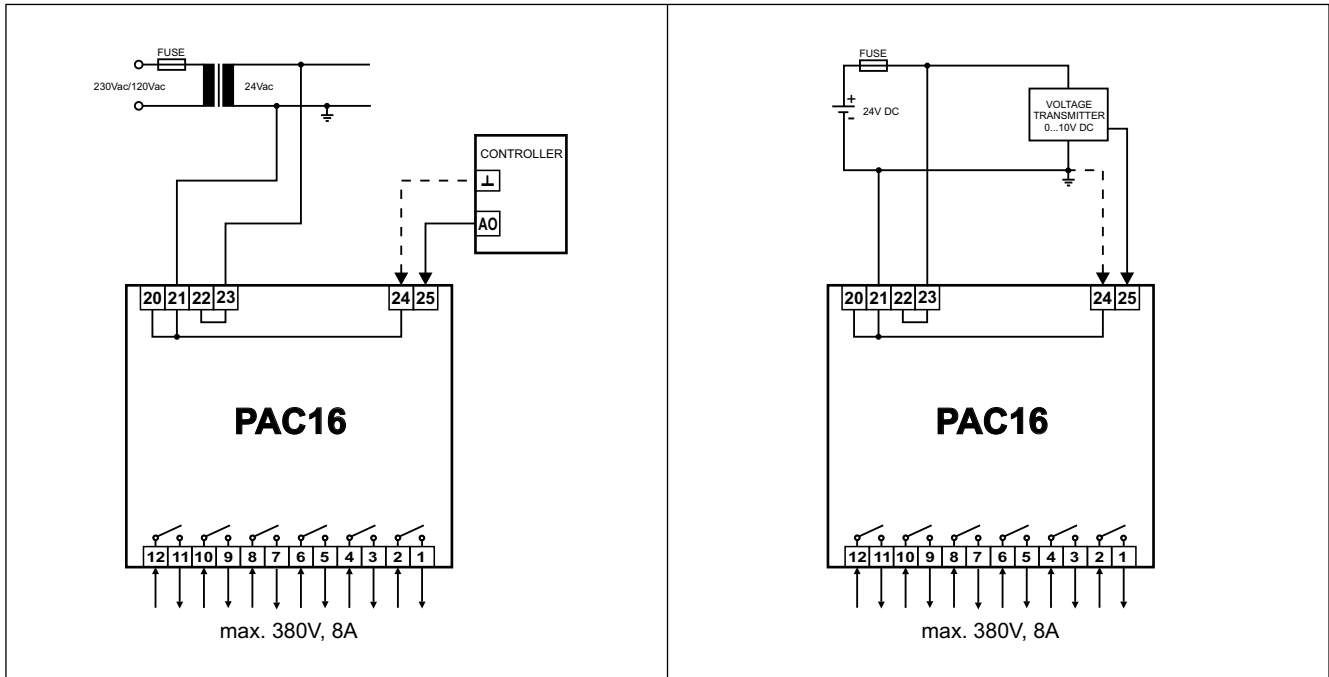

Fig.5 Example ways of connecting the PAC16.

Terminals 20 and 22 are supporting, for example, to provide power to other modules. Connection the terminal 24 to the ground of the controller (voltage transmitter) is recommended.

June 2004, revised: June 2008