



APPLICATION

The relay module used to work as an executive element with an analog output of the controller to activate peripheral equipment requiring greater power.

DESCRIPTION

The USS112 is two relay module that converts the analog input signal (0 - 10V) from the controller to four discrete, voltageless output states. Relays have SPDT contacts. Built-in hysteresis circuit prevents contacts from "flickering" in switching points. LED diodes indicate output states according to enclosed diagram.

Fig.1 The USS112P module.

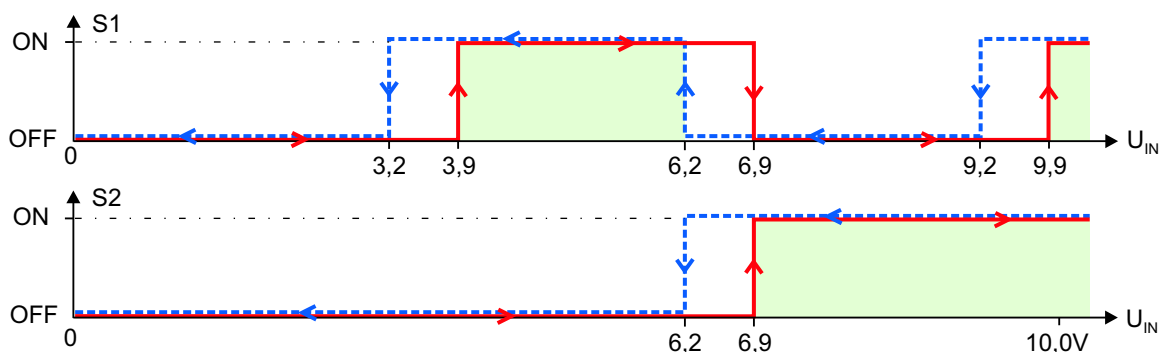

U_{IN} [V] increasing	U_{WE} [V] decreasing	S1	S2
0	0	○	○
3,9	3,2	●	○
6,9	6,2	○	●
9,9	9,2	●	●

■ - steady activation range

○ - opened contacts

● - closed contacts

adjust accuracy $\pm 0,5\%$

Fig.2 Switching diagram for NO contacts.

REMARK: The hysteresis width and thresholds can be individually set according to the specification.

USS112P

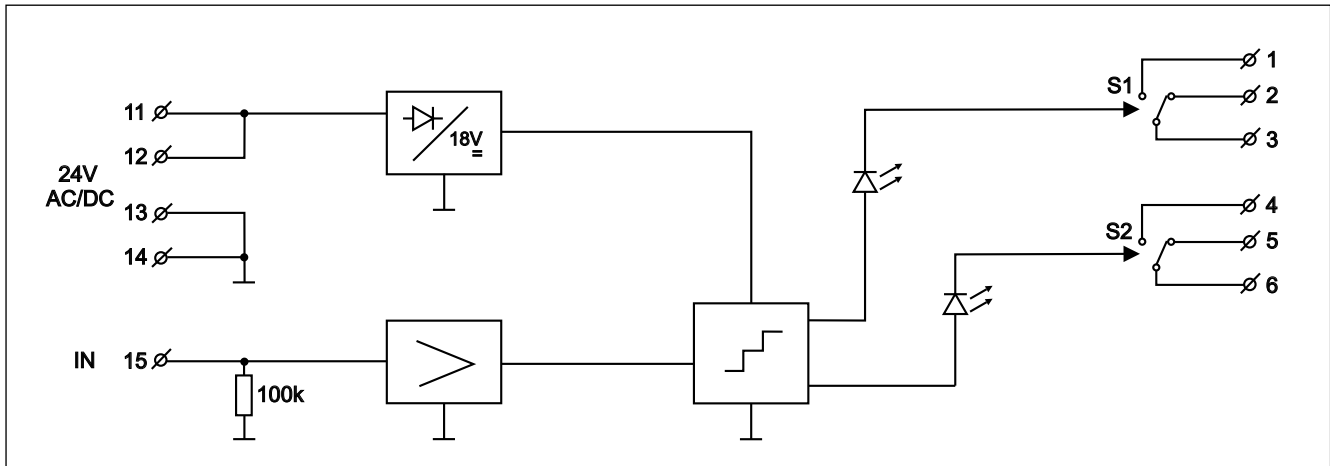

Fig.3 Connections of the USS112P.

TECHNICAL DATA

Power supply	24 V AC/DC \pm 15%
Max. current consumption	50 mA for 24 V AC 30 mA for 24 V DC
Input resistance	100k Ω
Contacts switching capacity alternating current $\cos\phi=1$ direct current	380V, 8A [2000VA] 32V, 8A
Mechanical endurance of contacts	2×10^7 operations
Protection class of the case	IP-40
Protection class of terminals	IP-20
Ambient temperature range	-10...+55°C
Diameter of terminals	2,5 mm ²
Protections	against reverse polarisation
Mounting	DIN-35 or DIN-32 rail
Dimensions (L x W x H)	96mm x 48mm x 42mm
Weight	115 g

June 2004, revised: April 2008