

APPLICATION

The relay module used to work as an executive element with an analog output of the controller to activate peripheral equipment requiring greater power. Among others it can control a single-stage gas burner and a boiler feed pump, enclosing only the pump, the burner with the pump and only the burner.

DESCRIPTION

The USS121 is functional equivalent of the MK1+P module, that converts the analog input signal (0 - 10V) from the controller to four discrete, voltageless output states. Relays have SPST-NO contacts. Built-in hysteresis circuit prevents contacts from "flickering" in switching points. LED diodes indicate output states according to enclosed diagram.

Fig.1 The USS121 module.

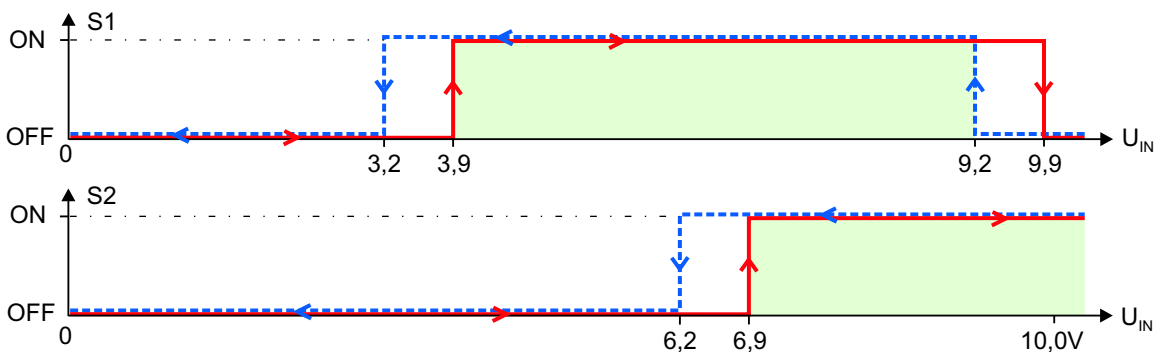

U_{IN} [V] increasing	U_{IN} [V] decreasing	S1	S2
0	0	○	○
3,9	3,2	●	○
6,9	6,2	●	●
9,9	9,2	○	●

■ - steady activation range

○ - opened contacts

● - closed contacts

adjust accuracy $\pm 0,5\%$

Fig.2 Switching diagram.

REMARK: The hysteresis width and thresholds can be individually set according to the specification.

USS121

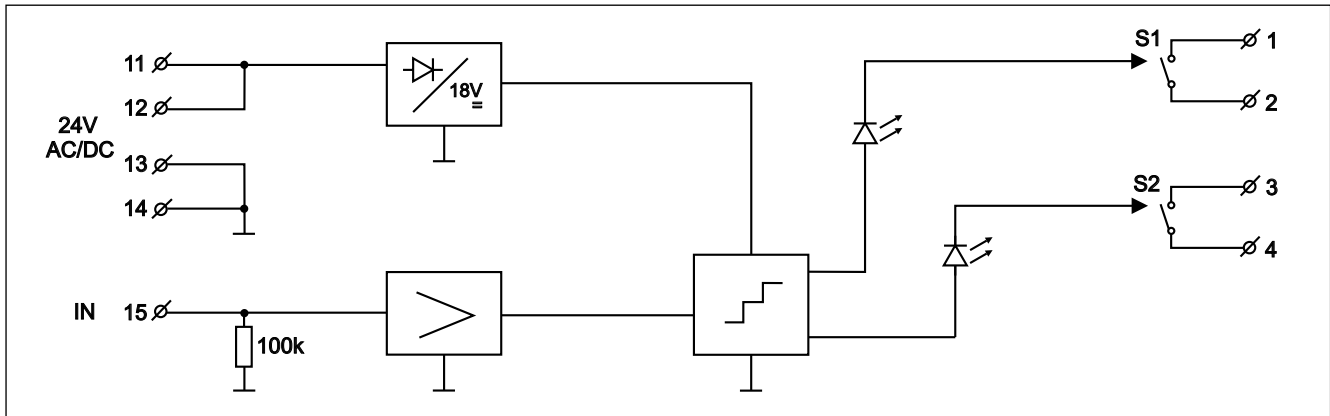

Fig.3 Connections of the USS121.

TECHNICAL DATA

Power supply	24 V AC/DC \pm 15%
Max. current consumption	50 mA for 24 V AC 30 mA for 24 V DC
Input resistance	100k Ω
Contacts switching capacity alternating current $\cos\phi=1$ direct current	380V, 8A [2000VA] 32V, 8A
Mechanical endurance of contacts	2×10^7 operations
Protection class of the case	IP-40
Protection class of terminals	IP-20
Ambient temperature range	-10...+55°C
Diameter of terminals	2,5 mm ²
Protections	against reverse polarisation
Mounting	DIN-35 or DIN-32 rail
Dimensions (L x W x H)	96mm x 48mm x 42mm
Weight	115 g

June 2004, revised: April 2008