

APPLICATION

The relay module used to work as an executive element with an analog output of the controller to activate peripheral equipment requiring greater power. Among others it can control a three-stage gas burner, a set of heaters, three pumps system, etc.

DESCRIPTION

The USS123 is functional equivalent of the MCAS3-3 module, that converts the analog input signal (0 - 10V) from the controller to four discrete, voltageless output states. Relays have SPST-NO contacts. Built-in hysteresis circuit prevents contacts from "flickering" in switching points. LED diodes indicate output states according to enclosed diagram.

Fig.1 The USS123 module.

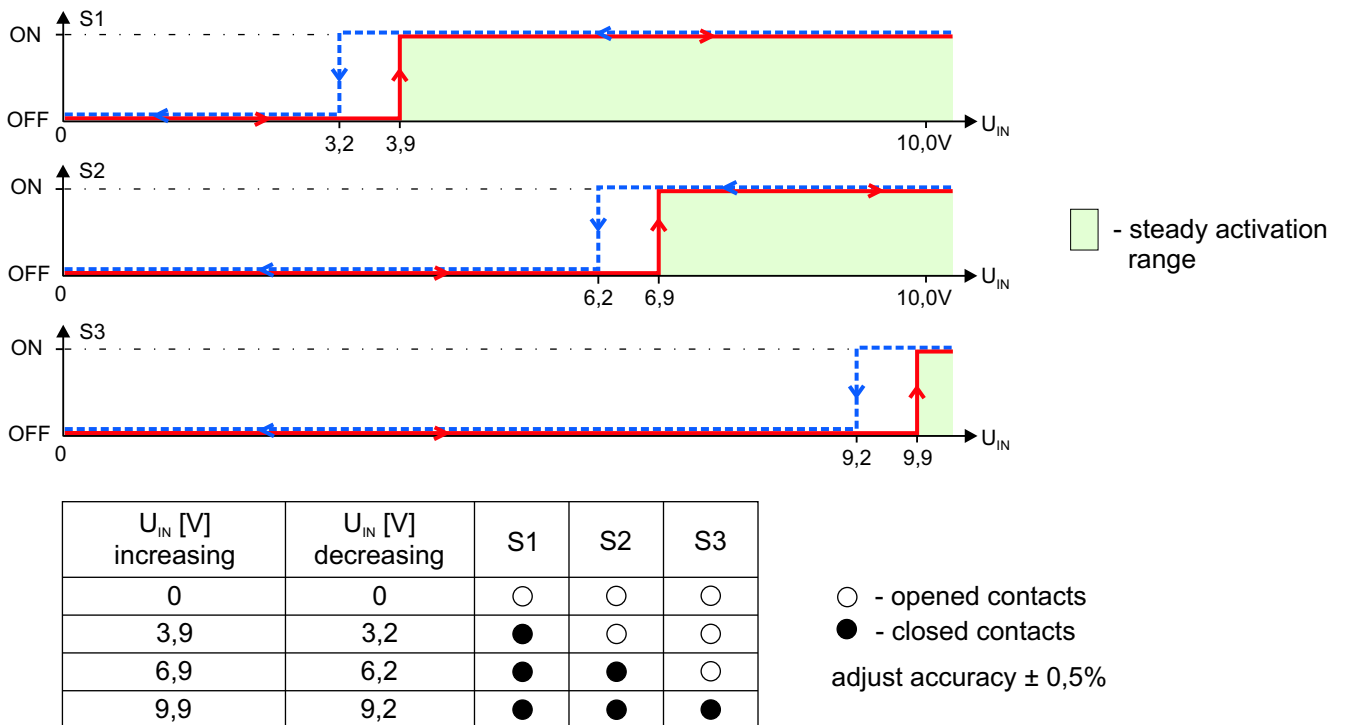

Fig.2 Switching diagram.

REMARK: The hysteresis width and thresholds can be individually set according to the specification.

USS123

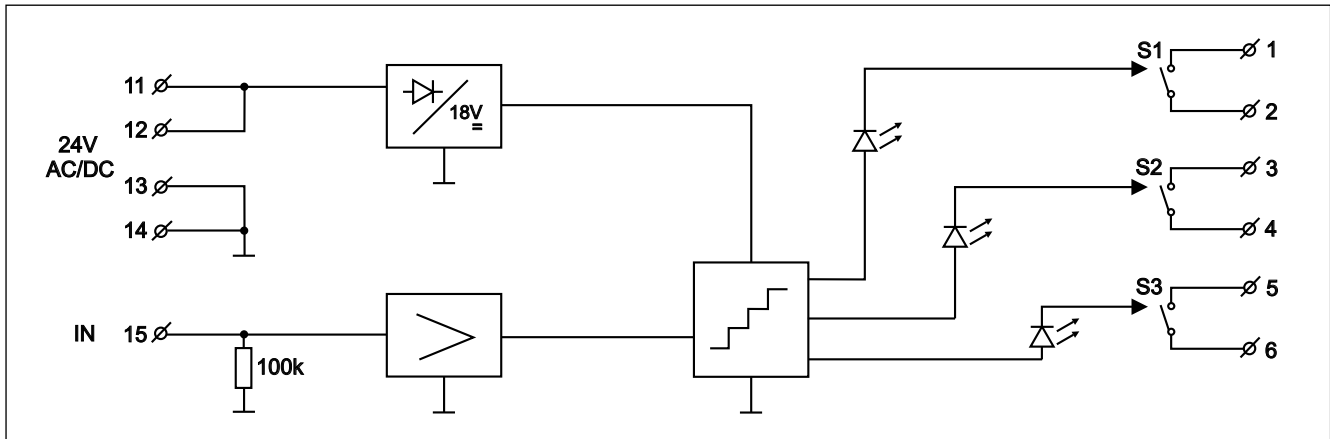

Fig.3 Connections of the USS123.

TECHNICAL DATA

Power supply	24 V AC/DC \pm 15%
Max. current consumption	74 mA for 24 V AC 40 mA for 24 V DC
Input resistance	100k Ω
Contacts switching capacity alternating current $\cos\phi=1$ direct current	380V, 8A [2000VA] 32V, 8A
Mechanical endurance of contacts	2×10^7 operations
Protection class of the case	IP-40
Protection class of terminals	IP-20
Ambient temperature range	-10...+55°C
Diameter of terminals	2,5 mm ²
Protections	against reverse polarisation
Mounting	DIN-35 or DIN-32 rail
Dimensions (L x W x H)	96mm x 48mm x 42mm
Weight	125 g

June 2004, revised: February 2008