

Fig.1 The USS136NZ module.

### APPLICATION

The relay module used to work as an executive element with an analog output of the controller to activate peripheral equipment requiring greater power. Among others it can control gas burners sets, heaters set, pumps system, etc. It is used in systems where on voltage decay circuits closing is required.

### DESCRIPTION

The USS136NZ is six relay module that converts the analog input signal (0 - 10V) from the controller to seven discrete, voltageless output states. Relays have SPST-NC contacts. Built-in input voltage level detection circuit allows enforce logical signals without transition states (no short switching of contacts). An important parameter is **the input signal settling time**. Typically it is 400ms and can be adapted to the needs of the customer in the range of 20ms up to several

minutes. Time should be chosen to be equal to or greater than the output signal settling time of the controller, which proofing the modul for short-term interference. The hysteresis circuit prevents contacts from "flickering" in switching points. LED diodes indicate output states according to enclosed diagram.

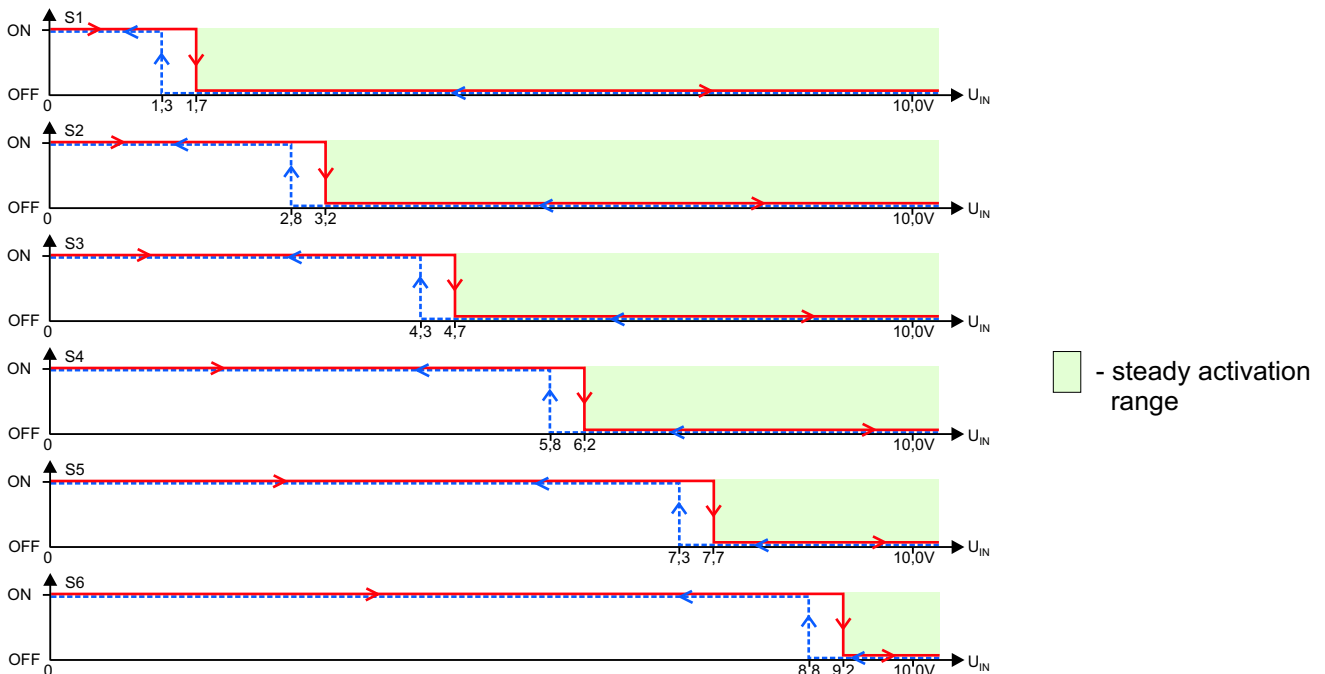

Fig.2 Switching diagram.

**REMARK:** The hysteresis width and thresholds can be individually set according to the specification.

# USS136NZ

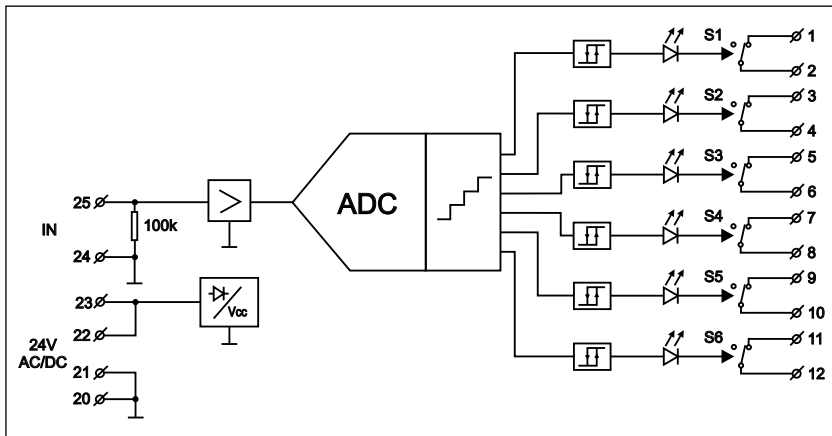

Fig.3 Connections of the USS136NZ.

$U_{IN}$ [V] increasing	$U_{IN}$ [V] decreasing	S1	S2	S3	S4	S5	S6
0	0	●	●	●	●	●	●
1,7	1,3	○	●	●	●	●	●
3,2	2,8	○	○	●	●	●	●
4,7	4,3	○	○	○	●	●	●
6,2	5,8	○	○	○	○	●	●
7,7	7,3	○	○	○	○	○	●
9,2	8,8	○	○	○	○	○	○

● - closed contacts, LEDs switched-off  
○ - opened contacts, LEDs switched-on  
adjust accuracy  $\pm 0,5\%$

Fig.4 Table of states.

## TECHNICAL DATA

Power supply	24 V AC/DC $\pm 10\%$
Max. current consumption	130 mA for 24 V AC 60 mA for 24 V DC
Input resistance	100k $\Omega$
Input voltage	0 - 10V
Input signal settling time	400ms
Hysteresis width	0,4V
Contact switching capacity alternating current $\cos\varphi=1$ direct current	380V, 8A [2000VA] 32V, 8A
Mechanical endurance of contacts	$2 \times 10^7$ operations
Protection class of the case	IP-40
Protection class of terminals	IP-20
Ambient temperature range	-10...+55°C
Diameter of terminals	2,5 mm <sup>2</sup>
Protections	against reverse polarisation
Mounting	DIN-35 or DIN-32 rail
Dimensions (L x W x H)	96mm x 70,5mm x 42mm
Weight	190 g

June 2004, revised: April 2008